

CapTel® 840 PLUS

Analog Mode

Setup Guide for Analog Mode

What is in the Box?

Your *CapTel* 840 PLUS includes the following parts:



- *CapTel* 840 PLUS Phone
- Telephone Cord



- Power Adapter – to plug into a wall outlet



- *CapTel* How-to Guide and *CapTel* Setup Guide



Important! Use only the power adapter that came in the box with your *CapTel* 840 PLUS

Setting Up Your *CapTel* 840 PLUS

STEP 1 – Select a Location

Set up the *CapTel* 840 PLUS in a place where:

- There is a telephone jack nearby (must be an analog line or DSL service with a filter).
- There is an electrical outlet nearby.
- The surface it will be set on, or mounted to, is stable and secure.
- The area is protected from excessive heat or humidity.

STEP 2 – Connect to your Telephone Service

1. Plug one end of the telephone cord into the telephone jack labeled “Line 1” located on the back (top) edge of the *CapTel* 840 PLUS. See diagram next page. (Use the telephone cord included with your new *CapTel* 840 PLUS phone.)
2. Plug the other end of the telephone cord into a telephone wall outlet.

STEP 3 – Connect to a Power Outlet

1. Plug the power adapter in the power socket labeled “Power” located on the back (top) edge of the *CapTel* 840 PLUS.
2. Plug the power adapter into a wall outlet or power strip. The *CapTel* display screen will light up to let you know power is connected.

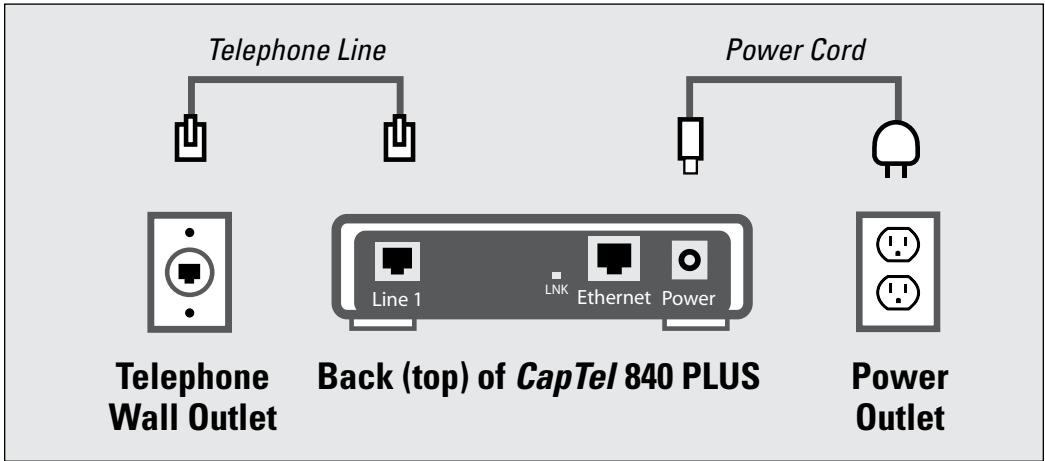

WARNING: Be sure to use only the power adapter that came with your *CapTel* 840 PLUS. Using any other power adapter may damage your phone.

TIP: Plug your power adapter into an electrical power surge protector to protect your *CapTel* 840 PLUS from damage caused by unspecified electrical voltage or lightning.

STEP 4 – Select a Language

You can set *CapTel* 840 PLUS for either English or Spanish. The *CapTel* menu options and conversation captions will appear in whichever language you select.

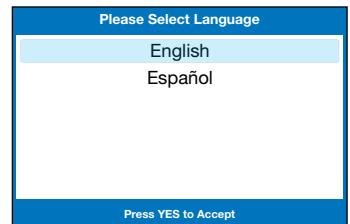

1. Select which language you would like. Press the **UP** arrow or **DOWN** arrow until the language you want is highlighted.



2. Press the **YES** button to accept.

STEP 5 – Enter a Dialing Prefix

In some office settings, you may need to dial a 9 or other number to get an outside line. This number must be entered in the Dialing Prefix menu in order for captions to work properly.



If you do *NOT* need a dialing prefix, press the **NO** button. Move to Step 6.

If you *DO* need a dialing prefix:



1. Press the **YES** button.
2. Use the dialing keypad to enter the number you need to get an outside line. Use the **DOWN** arrow button to backspace and press the **UP** arrow button to add 2-second delay, which will appear as a comma (,).
3. When the number is entered, press the **YES** button to save.

If you enter a Dialing Prefix, your *CapTel* phone will automatically dial the number for you at the start of every captioned call.

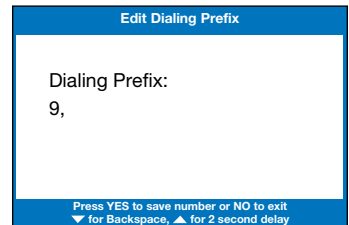
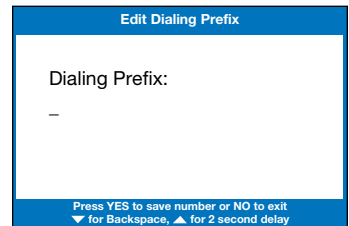
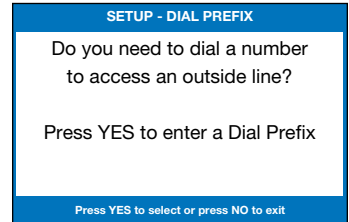

STEP 6 – Phone Mode Check

Your *CapTel* 840 PLUS checks which MODE your phone is operating in, either analog mode or IP mode.

If the Mode setting is correct, the display screen indicates No Mode Change Needed.

If a Mode Change is required, your *CapTel* phone will automatically switch to the correct mode. Watch the display for directions.

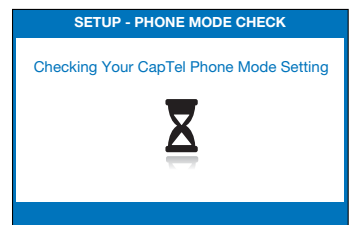

STEP 7 – Set the Time and Date

You only need to set the time and date the first time you set up your *CapTel* phone (or after a power outage).

1. Do you live in an area that observes Daylight Savings Time? If so press the **YES** button. If not, press the **NO** button.



2. *CapTel* shows you the default time and date setting. Use the **UP** or **DOWN** arrow buttons to move the blue highlight over the number that you want to change.

3. On the dialing pad, press the key that lists the number you want to use.

Example: To set the time for 11:30, press the “1” key twice, then press the “3” key followed by the “0” key.

NOTE: *When you enter the date setting, only the last two numbers in the year can be changed.*



4. When you have set the time and date, press the **YES** key to save.

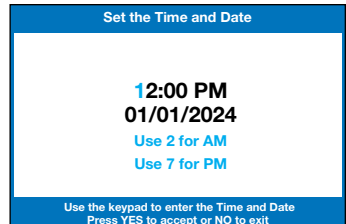
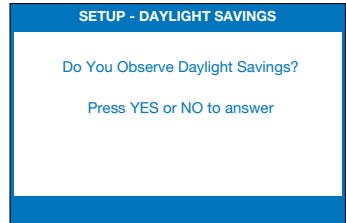

STEP 8 – Telephone Line Quality Test

A high-quality telephone line connection helps ensure that captions are not interrupted during your calls. To test the line quality, *CapTel* dials in to a special testing program. The *CapTel* screen indicates the test results.

If the test indicates poor line quality, you may still be able to make/receive calls, but you might experience problems with the captions.

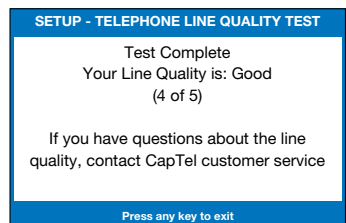
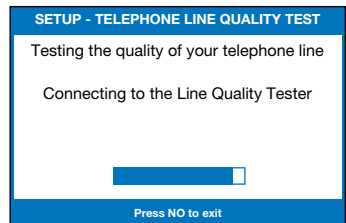

STEP 9 – Do you have Call Waiting service?

If yes, please follow the instructions for “Setting a Call Waiting Block” in the *CapTel* 840 PLUS How-to Guide.

Congratulations! You are ready to start making calls!

Getting Help

We’re here to help. Use any of these ways to contact us:

CUST
SERV



CUST SERV Button

Pick up the handset and press the **CUST SERV** button to automatically speed dial directly to our helpful Customer Service team.
(Available 24 hours a day, 7 days a week. Closed on major holidays.)

Help materials are also available online at our website.



Phone: 1-888-269-7477 *(Available 24 hours a day, 7 days a week)*

FAX: (608) 204-6167



Mail: CapTel Customer Service
450 Science Drive
Madison, WI 53711



Email: CapTel@CapTel.com

Online: www.CapTel.com *(Live Chat help available at our website)*

▲ Please familiarize yourself with Dialing 911 in an Emergency in the How-to Guide.

Getting Started

Easy steps to start using your *CapTel* phone! For full instructions, please see the *CapTel 840 PLUS* How-to Guide.

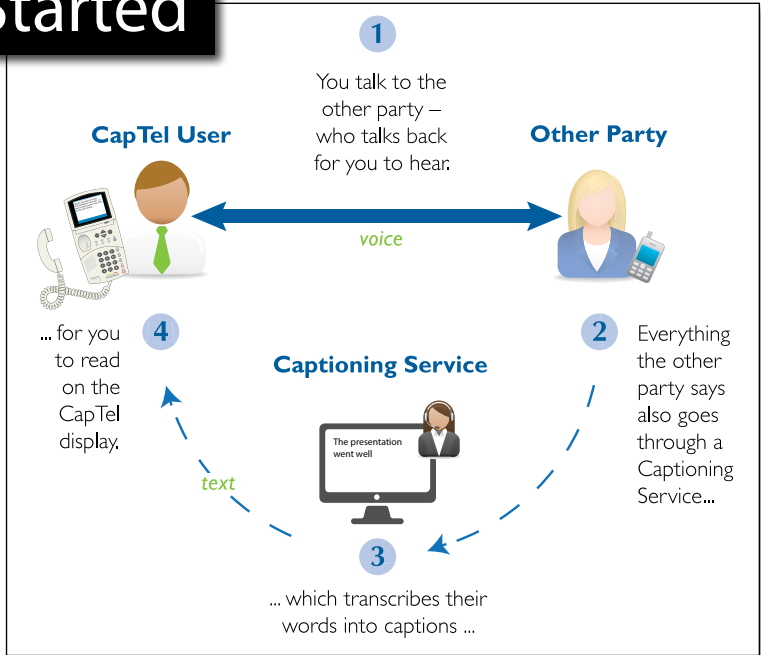

Placing a Call

1. Make sure the red light around the **CAPTIONS** button is on. Press the **CAPTIONS** button to turn the light on or off.
2. Lift the handset or press the **SPEAKER** button.
3. Dial the phone number of the person you wish to call. Remember to include a 1 and the area code if dialing long distance.
4. You will see a message letting you know that the Captioning Service is connecting the call.
5. Listen or watch the screen to know when someone answers. Begin your conversation as you normally would.

CAPTIONS



When you are done with your call, hang up the handset or press **SPEAKER** again.

Signal Meter shows sounds on the line

Dial a Number
or Press Speed Dial

Dialing:
1-555-333-1234

Waiting for Captions

(CapTel CA# C1234) (Tones) (Ring) (Ring) (Ring) (M) Hello this is John who is calling please?

Press ▲ to Review the Conversation

Getting Captions on Incoming Calls

When someone calls you, they must dial the Captioning Service first, then enter your phone number in order for you to get captions. If the incoming call is not placed through the Captioning Service, the call will not be captioned. You cannot turn captions on/off in the middle of a call.

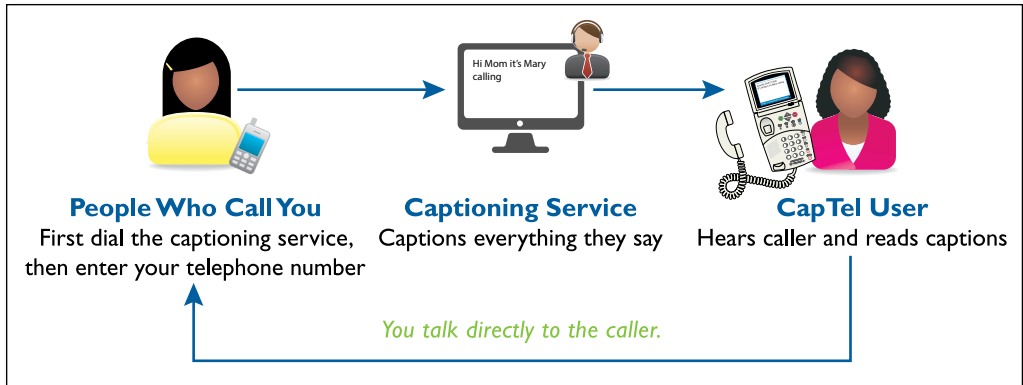

1. The person calling you first dials the toll-free Captioning Service: 1-877-243-2823 (For other numbers, including for California or Texas calls or Spanish-to-Spanish captioning, please see page 1 of the How-to Guide.)
2. The caller hears a recording asking them to enter your phone number and press the # key.
3. When your CapTel phone rings, pick up the handset to answer.
4. The display shows the status as your CapTel phone connects to the Captioning Service.
5. Say "Hello" and begin your conversation as soon as you see that the call has connected.

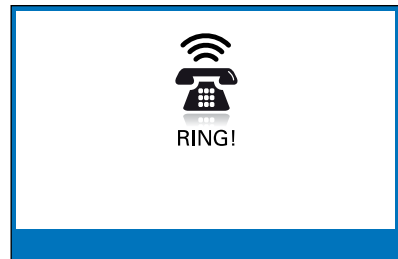

CapTel is the latest innovation from  **Ultratec**.

©2014–2024 Ultratec, Inc. All rights reserved.

Ultratec and *CapTel* are registered trademarks of Ultratec, Inc.